

# PAC \_ Démarches de Progrès

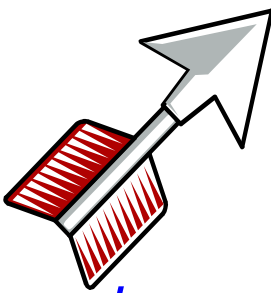

*Démarches de Progrès*

1

## CHOISIR LA DÉMARCHE

**PROGRESSIF**      OU      **COUP DE POING**

<p><b>Progrès continu « Kaizen »</b></p> <p><i>Amélioration continue et progressive étalée dans le temps impliquant la contribution de tous.</i></p>	<p><b>« Re-engineering »</b></p> <p><i>Re-conception radicale et complète de l'ensemble des processus de l'entreprise et de sa structure.</i></p>
--	---

2

# PAC \_ Démarches de Progrès

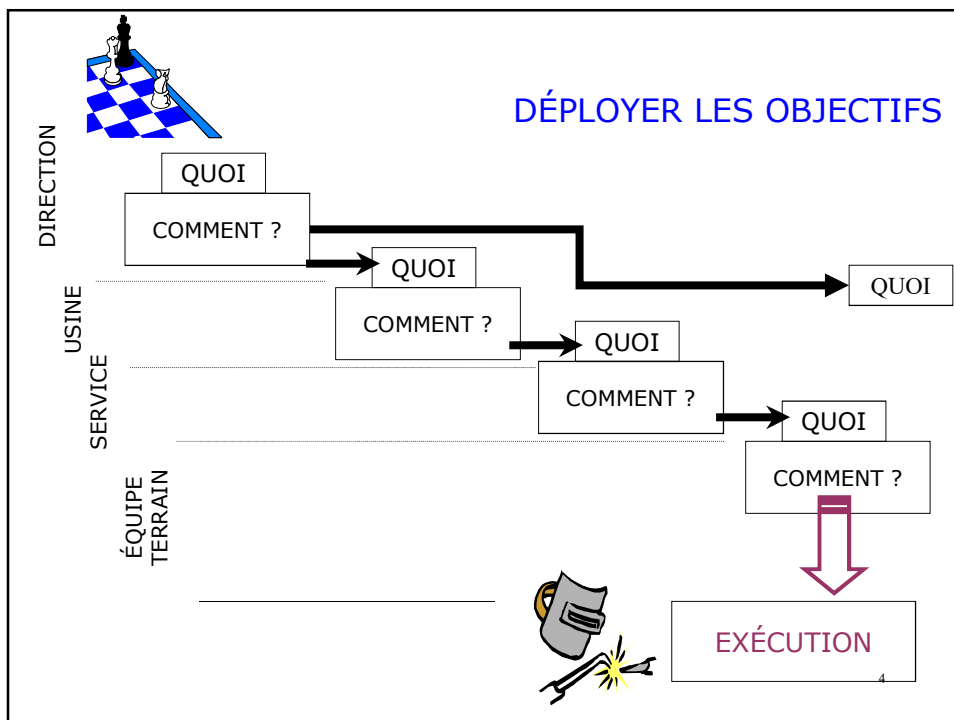
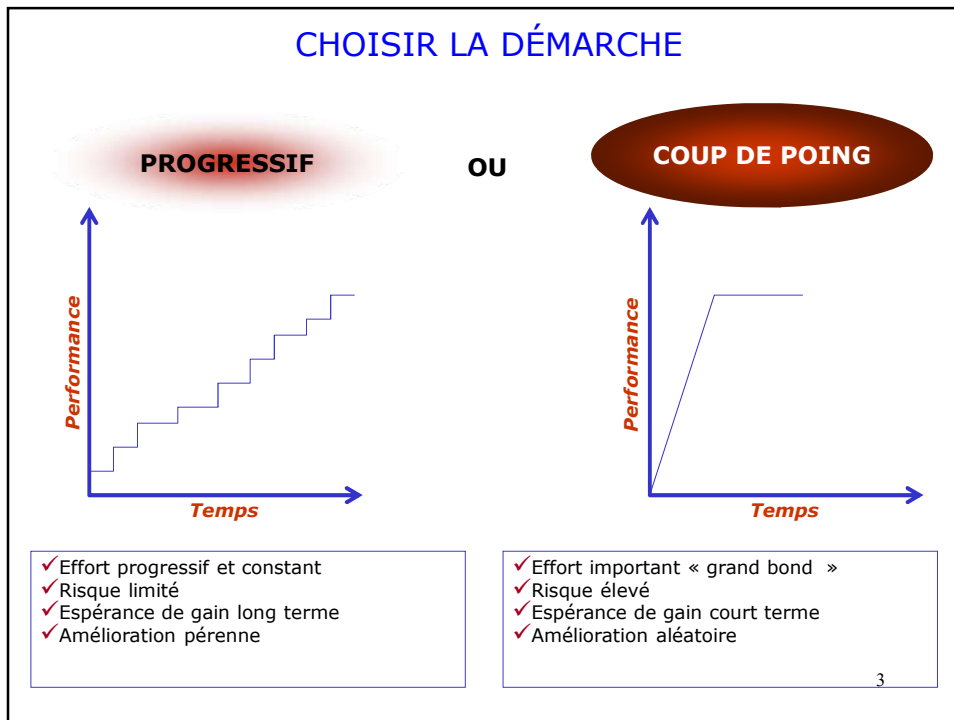

# PAC \_ Démarches de Progrès

